

Countum Group

# SATAM

Metering Solutions



## Gravity feed metering units

### ZCE 10 & ZCE 11-80

ZCE 10 and ZCE 11-80 are measuring units operating by gravity for tank trucks unloading. They are used for measurement of fuels delivered by gravity from the truck to a storage tank. ZCE 10 is an on-board metering unit. ZCE 11-80 is a reception unit.

Equipped with mechanical or digital registers, they allow to determine and to verify the delivered quantities without any contestation.

Flow computers

Measuring systems

Flow meters

Accessories

#### Sectors of application

- Tanker truck unloading operation
- Measurement of white product and biofuels
- On-board metering for tank truck

#### High reliability measuring system

A rugged and reliable metering technology  
PD meter with moving blades.

Excellent long term stability.

Integrated strainer and air eliminator.

Measurement accuracy independent of liquid viscosity.

#### A high flexibility of installation

Fully assembled and tested in production facility.

Direct connection to truck and storage tank tubing.

Gas elimination device without connection to external atmosphere.

Compact design for easy installation on tank truck.

#### A safe and easy-to-use technology

Automatic gas purge system to allow start-up with empty tubing.

Filtering with possibility of automatic clogging detection.

#### Key points

##### Self-powered technology

No need for power supply for mechanical register version.

##### Low maintenance costs

Simple and robust construction with minimal moving mechanical components.

##### Low installation cost

Can be mounted on a trolley as a mobile metering unit.

##### Safe Use

Measuring system supplied fully assembled and factory tested in order to ensure a maximum reliability.

##### Measurement stability and accuracy

Measurement accuracy guaranteed over a period of many years without any deviation in the calibration curve.

##### Modular Design

Extensive line of accessories to create customized measurement applications.

# Technical data - Gravity feed metering units

Measuring system		ZCE 10	ZCE 11-80
Maximum flow rate	m <sup>3</sup> /h - L/mn - USGPM	45 - 750 - 200	
Applications		On-board gravity feed metering unit	Gravity feed metering unit for product reception
Measured parameters		Actual volume, temperature-corrected volume*, mass*, flow rate**, temperature* (* : only for electronic register version ; ** : option for mechanical register version)	
Measured liquids		Petrol, premium fuels, diesel, E5...E85, bio-diesel, kerosene, fatty acid methyl ester, oils	
Equipment	Gas elimination device – Stainer	Model EC 35 Filtering 50 to 450 μ (270 to 40 Mesh) depending on the liquid Gas release controlled by float and differential valve	
	PD meter	Model ZC 17-80	
	Temperature measurement	4-wire Pt 100 (option for electronic calculator version)	
	Stop valve	Model XAD 49 Flow controlled by gas elimination device	
	Manual Valve	Model XAD 50 Included for unloading control	-
	Flow register	Mechanical register model VR, preset*, printer*, pulser*, (* : option) or Equalis electronic register with display, secure archiving of transactions	
Operating conditions	pressure	10 bar	
	viscosity	20cSt max. – contact us about higher viscosities	
	Liquid temperature	-10 to + 80 °C	
	Ambient temperature	Standard -25 to + 55 °C ; Option -40 to + 55 °C Contact us about higher or lower temperatures	
Metrological performance	Volume accuracy	< +0.15 % - Option < +0.1 % - for measuring range 10 : 1	
	Volume repeatability	< +0.02 %	
	Temperature accuracy	< 0.5 °C	
Installation	ATEX certification	Zone 1 - II 2 G	
Custody transfer approval		EC Type Examination Certificate n°LNE 28039 Type compliance certificate OIML R117 n°LNE-24351(ZC17)	
Dimensions and weight		120 kg	

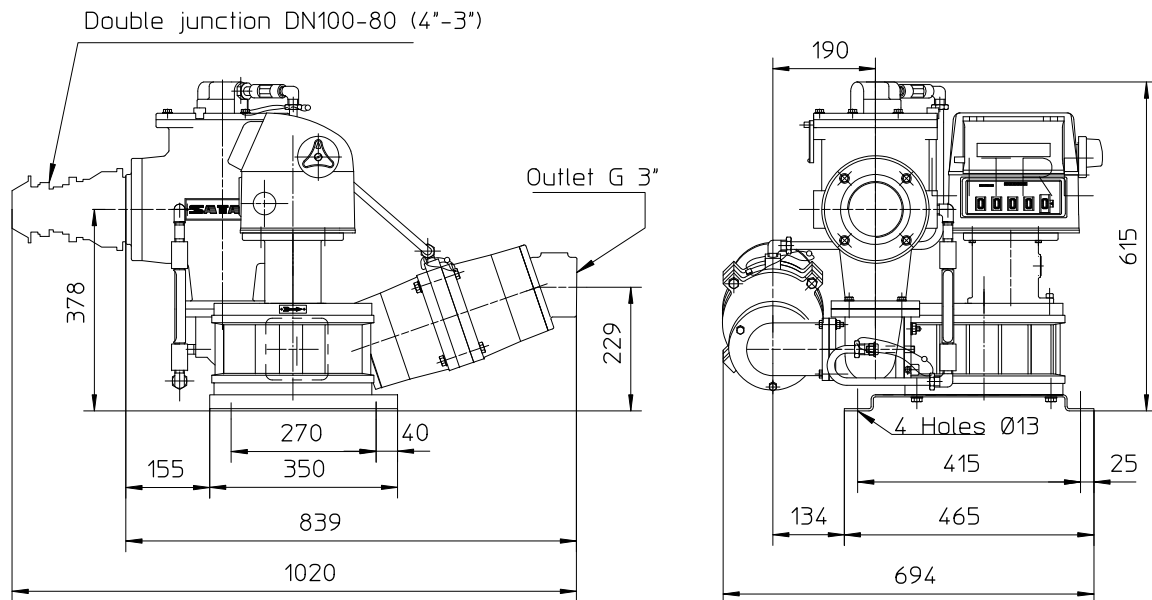

## Headquarters and Sales Department

PARIS NORD II  
Bat. le Gauvain - 47, allée des Impressionnistes  
BP 85012 Villepinte  
95931 Roissy CDG Cedex FRANCE  
Phone: +33 (0)1 48 63 02 11  
Fax: +33 (0)1 49 38 41 01  
E-mail: sales@satam.eu

## Manufacturing facility

Avenue de Verdun - CS 60129  
14700 Falaise FRANCE  
Phone: +33 (0)2 31 41 41 41  
Fax: +33 (0)2 31 40 75 61



[www.satam.eu](http://www.satam.eu)