

Countum Group

# SATAM

Metering Solutions



## Reception metering unit for pressurized liquids

### ZCE 29

ZCE 29 is a reception measuring unit designed for unloading of tank truck, rail tanker and ship. It is provided with a gas elimination device. This enables the complete delivery measurement to be reliable and accurate even in case of liquid - gas mixture into the up-stream delivery hose. It is a compact design and can easily be installed in small areas.

Flow computers

Measuring systems

Flow meters

Accessories

#### Sectors of application

- Tanker truck unloading operations
- Hydrocarbon reception from rail tanker
- Fuel delivery to service station
- Measurement of petroleum products and bio-fuels

#### Design of the metering system

##### Integrated strainer and air eliminator

Gas elimination pipe without connection to external atmosphere.

Automatic gas purge system to start unloading with empty tubing.

Filtering with possibility of automatic clogging detection.

##### Robust and reliable measuring design

PD meter with moving blades.

Excellent long term stability.

Measurement accuracy independent of liquid viscosity.

##### Mechanical and electronic register

Mechanical register for a self-powered measuring system.

Electronic register for a secured back-up of transactions.

#### Key points

##### Low maintenance costs

Simple and robust construction with minimal moving mechanical components.

##### Low installation cost

Compact metering unit for installation in smaller areas.  
Direct connection to the up-stream centrifugal pump.

##### Safe Use

Measuring system supplied fully assembled and factory tested in order to ensure a maximum reliability.

##### Measurement stability and accuracy

Measurement accuracy guaranteed over a period of many years without any deviation in the calibration curve.

##### Modular Design

Extensive line of accessories to create customized measurement systems.

# Technical data - Reception measuring unit

Measuring system		ZCE 29-80	ZCE 29-150
Application		Reception or transfer metering of pressurized liquid hydrocarbons	
Maximum flow rate	m <sup>3</sup> /h - L/mn - USGPM	80 - 1333 - 210	150 - 2500 - 660
Measured parameters		Actual volume, temperature-corrected volume*, mass*, flow rate**, temperature* (* : only for electronic register version ; ** : option for mechanical register version)	
Measured medium		Petrol, premium fuels, diesel, E5...E85, bio-diesel, ethanol, methanol, kerosene, fatty acid methyl ester oils	
Equipment		3" ASA 150 RF	4" ASA 150 RF
Connection : Flanges Gas elimination device – Strainer		Model EC 31 Filtering 50 to 450µ (270 to 40 Mesh) depending on the liquid Gas release controlled by float and differential valve Gas elimination pipe without connection to external atmosphere	
PD Meter		ZC 17 - 80	ZC 17 - 150
Temperature measurement		4-wire Pt100 (option for electronic calculator version)	
Non return valve		To be installed at the ZCE 29 outlet	
Multi-functions valve *		Option to replace the non return valve, only for electronic register version, small and large flows, authorization, flow limitation, electric controlled	
Flow register		Mechanical register model VR with preset*, printer*, pulser*, (* : option) or Equalis electronic register with display, secure archiving of transactions	
Centrifugal electro-pump		Not supplied - to be imperatively installed upstream ZCE 29	
Air relief valve		To be installed up-stream the pump Connection : ½" Maximum operating pressure 34 bar @ 38 °C	
Operating conditions		Pressure 10 bar max.	
Viscosity		20 cSt max. – Consult us for higher values	
Liquid temperature		-10 to + 80 °C	
Ambient temperature		Standard -25 to + 55 °C ; Option -40 to + 55 °C Contact us about higher or lower temperatures	
Metrological performances		Volume accuracy ≤ ±0.15 % - Option ≤ ±0.1 % - for measuring range 10 : 1	
Volume repeatability		≤ ±0.02 %	
Temperature accuracy		≤ 0.5 °C	
ATEX certification		Zone 1 ; II 2 G	
Custody transfer approval		CE MID Evaluation certificate n°LNE 11123 (ZC 17) Type compliance certificate OIML R117 n°LNE-245351 (ZC 17)	
Dimensions (mm) and weight		ZCE 29-80	ZCE 29-150
Distance between flanges (A)		961	1096
Width (B)		451	524
Height (C)		740	758
Weight (Kg)		105	125

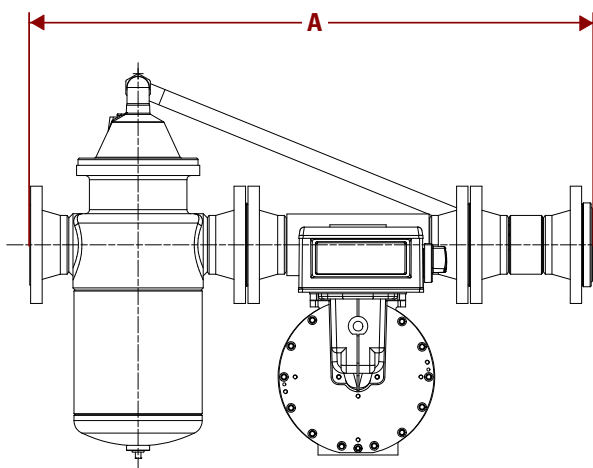
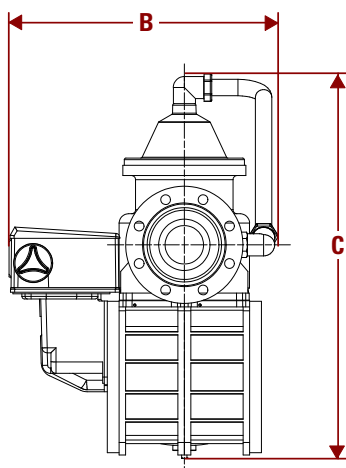

## Headquarters and Sales Department

PARIS NORD II  
Bat. le Gauguin - 47, allée des Impressionnistes  
BP 85012 Villepinte  
95931 Roissy CDG Cedex FRANCE  
Phone: +33 (0)1 48 63 02 11  
Fax: +33 (0)1 49 38 41 01  
E-mail: sales@satam.eu

## Manufacturing facility

Avenue de Verdun - CS 60129  
14700 Falaise FRANCE  
Phone: +33 (0)2 31 41 41 41  
Fax: +33 (0)2 31 40 75 61



[www.satam.eu](http://www.satam.eu)