

Equipment	Master meter		
Model	ZCM17-150 with mechanical register		
Performance characteristics			
Measured liquids	Liquid hydrocarbons, industrial oil, fatty acid esters, ethanol		
Static pressure	max	15 bar	
Inlet pressure	max	10 bar	
Liquid temperature	min / max	- 10°C / +90°C	14°F / +194°F
Working flow rate	min / max	15 m ³ /h - 250 L/min - 66 USGPM / 150 m ³ /h - 2500 L/min - 660 USGPM	
Liquid viscosity	max	20 mm ² /s (MID) - 800 mm ² /s - at operating conditions	
Accuracy	< 0.1% of measured value		
Repeatability	< 0.02% of measured value		
Pressure drop	See attached pressure drop chart		
Calibration report	According to OIML R117-1 / One calibration report per operating viscosity Calibration at 7 flowrates with 2 repetitions per flow rate Calibration at 15, 37, 60, 82, 105, 127, 150 m ³ /h		
Flowmeter manifold			
Connection nominal size	DN 100 / 4"		
End connection style	Flanges ASA 150 RF		
Material	Steel (EN 1.0625) , Ductile iron (EN 5.3201) (option), Aluminum (EN AC-42200) (option)		
End connection style	Flanges ASA 150 RF		
Coating	Acrylic-Epoxy coating RAL5010, Marine Epoxy coating RAL5010 (option)		
Flowmeter body			
Body material	Ductile iron (EN 5.3201) , Ni resist iron (EN-JL3011) (option)		
Cap/end cover material	Carbon steel (EN 1.0625) with protective coating		
Seal/O-ring material	Viton, Nitrile (option for alcohols measurement)		
External coating	Acrylic-Epoxy coating RAL5010, Marine Epoxy coating RAL5010 (option)		
Measuring chamber			
Displacement element type	Sliding vanes flowmeter		
Cyclic volume	4,54 L - 1,12 USG		
Blades / Blades connection rods	Graphite / Stainless steel		
Rotor / Bearings	Aluminum (EN AC-42100) / Stainless steel (EN 1.4301)		
Swing joint	Viton, Nitrile (option for alcohols), PTFE (option for low ambient temperature)		
Drive train and adjuster			
Drive type / Accuracy adjuster type	Mechanical transmission / AB21		
Register			
Register type	Mechanical register		
Model / Accessories	VR7887, 5 digits / Preset with valve, printer, pulses transmitter		
Flowrate indicator			
Display	Indication in L/min, option: m ³ /h, USGPM		
Accessories			
Temperature measurement	Local display (option)		
Pressure measurement	Local display		
Trolley version (option)			
Trolley	Calibration device mounted on chassis with 4 pivoting wheels		
Connecting pipes between meter and hoses	Quantity 2, Steel (EN 1.2506)		
Flexible hoses / Connections	3mL / Loose type flanges 4"ASA 150lbs, TODO type couplings, CAMLOCK type couplings		
Isolating valve	Ball valve located downstream the meter (option)		
Drainage equipment	Manual drainage pump with purge valve, hoses and 2 release valves		
Environmental			
Ambient working temperature	min / max	-25°C, -40°C (option) / +55°C	-13°F, -40°F (option) / +131°F
Storage temperature	min / max	-40°C / +80°C	-40°F / +176°F
Certification			
ATEX	Zone 1 II 2 G		

SATAM sas**Headquarters & Sales Department**

Paris Nord 2 – Bâtiment Le Gauvain
47, allée des Impressionnistes – BP85012 – Villepinte
95931 Roissy CDG Cedex – France
Tel : +33 (0)1 48 63 02 11 – Fax: +33 (0)1 49 38 41 01
Email : sales@satam.eu

Manufacturing facility

Avenue de Verdun
14700 Falaise – France
Tel : +33 (0)2 31 41 41 41
Fax : +33 (0)2 31 40 75 61

Equipment	Master meter
Model	ZCM17-150 with mechanical register

Dimensions (trolley version)

Hoses for process connection are not shown on this drawing.

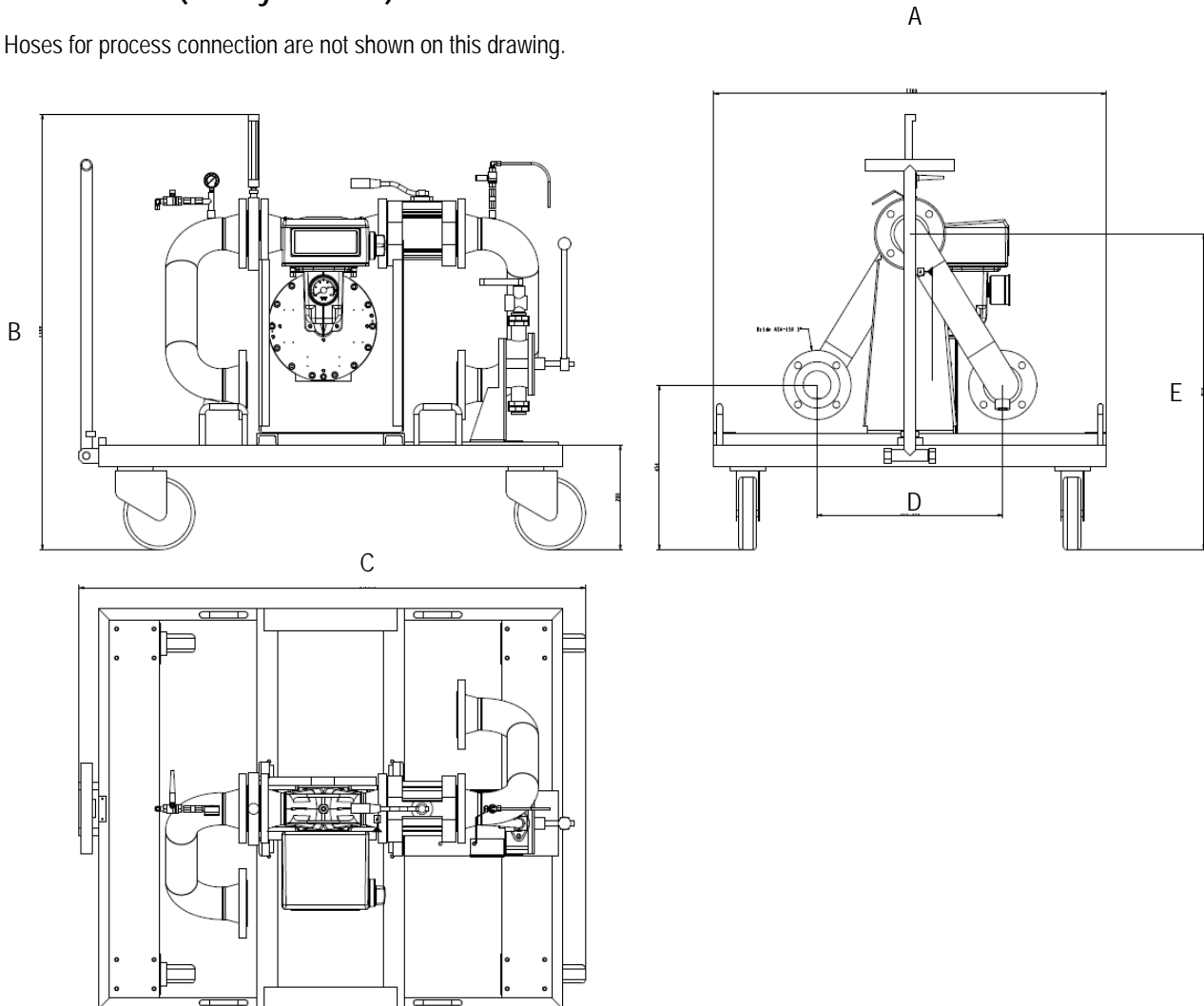

Dimensions (mm)	ZCM17-150
A	1100
B	1250
C	1419
D	560
E	920
Weight (kg)	300

SATAM sas

Headquarters & Sales Department

Paris Nord 2 – Bâtiment Le Gauvain
 47, allée des Impressionnistes – BP85012 – Villepinte
 95931 Roissy CDG Cedex – France
 Tel : +33 (0)1 48 63 02 11 – Fax: +33 (0)1 49 38 41 01
 Email : sales@satam.eu

Manufacturing facility

Avenue de Verdun
 14700 Falaise – France
 Tel : +33 (0)2 31 41 41 41
 Fax : +33 (0)2 31 40 75 61

Equipment	Master meter
Model	ZCM17-150 with mechanical register

Typical design of ZCM17 (trolley version)

Hoses for process connection are not shown on this drawing.

*: optional supply

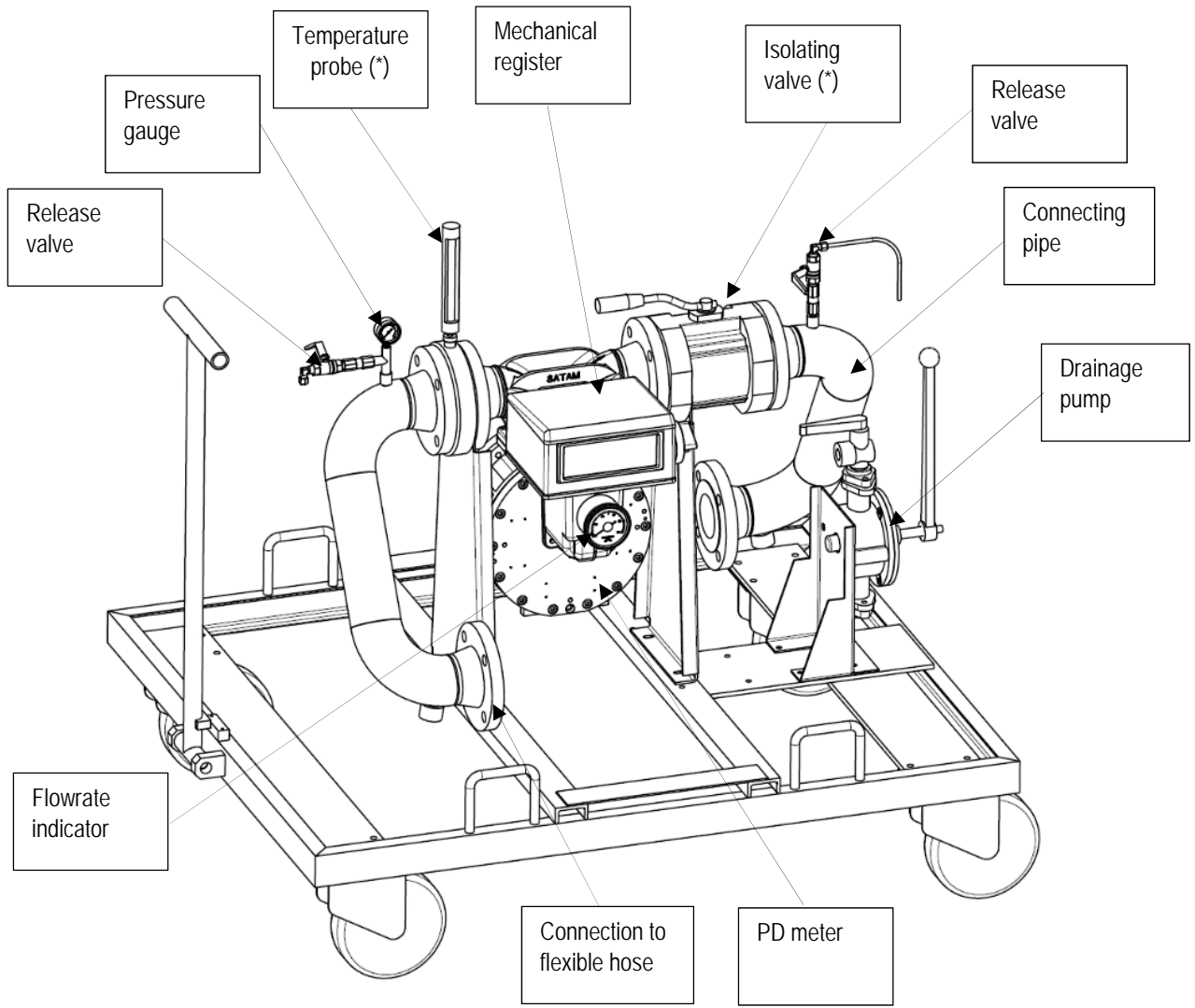

SATAM sas

Headquarters & Sales Department

Paris Nord 2 – Bâtiment Le Gauvain
 47, allée des Impressionnistes – BP85012 – Villepinte
 95931 Roissy CDG Cedex – France
 Tel : +33 (0)1 48 63 02 11 – Fax: +33 (0)1 49 38 41 01
 Email : sales@satam.eu

Manufacturing facility

Avenue de Verdun
 14700 Falaise – France
 Tel : +33 (0)2 31 41 41 41
 Fax : +33 (0)2 31 40 75 61